

WWW.THUNDAFLO.COM

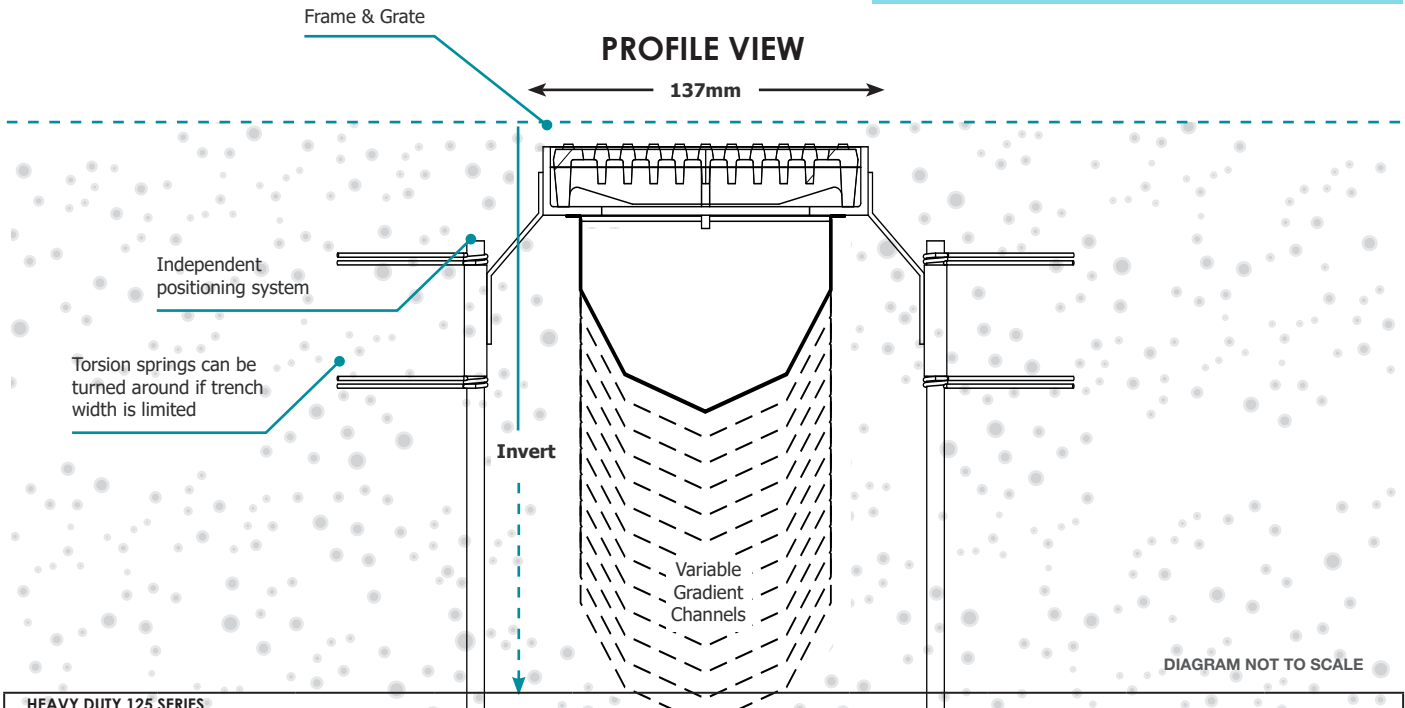

HEAVY DUTY 125 SERIES									
SECTION ID	SECTION MEASUREMENT				SECTION POSITION		SECTION HYDRAULICS ³		
River (R) - Variable Built-in-Fall									
Sections	Weight Excl. Grate (Kg's)	Length (Metres) ⁵	Start Invert (mm)	End Invert (mm)	Previous Upstream Section	Next Downstream Section	Built-in-Fall (%)	Max Design Velocity (M/s)	Max Design Flow Rate (L/s) ¹
HD125 R1-0.5	3.3	0.5 ⁴	153	162	-	R2 or T2 ⁴	1.50%	-	-
HD125 R1-1.0	6.6	1.0 ⁴	145	162	-	R2 or T2 ⁴	1.50%	-	-
HD125 R1-1.5	9.5	1.5 ⁴	138	162	-	R2 or T2 ⁴	1.50%	-	-
HD125 R1-2.0	12.4	2.0 ⁴	130	162	-	R2 or T2 ⁴	1.50%	-	-
HD125 R1-2.5	16.1	2.5 ⁴	123	162	-	R2 or T2 ⁴	1.50%	-	-
HD125 R1-3.0	19.0	3.0	115	162	-	R2 or T2 ⁴	1.50%	1.1	12
HD125 R2-3.0	19.3	3.0	162	194	R1	R3	1.00%	1.0	14
HD125 R3-3.0	19.7	3.0	194	219	R2	R4	0.75%	0.9	15
HD125 R4-3.0	20.1	3.0	219	239	R3	R5 or T5 ⁸	0.63%	0.8	16
(Z5) Zero Fall Section Length Extender can be inserted here²									
HD125 R5-3.0	20.4	3.0	239	259	R4 or T2 ⁴	R6	0.60%	0.8	17
HD125 R6-3.0	23.4	3.0	259	279	R5	R7	0.58%	0.8	19
HD125 R7-3.0	24.1	3.0	279	297	R6	R8	0.56%	0.8	20
HD125 R8-3.0	24.5	3.0	297	316	R7	R9 or T9 ¹³	0.55%	0.8	21
HD125 R9-3.0	24.8	3.0	316	334	R8 or T5 ⁸	R10	0.54%	0.8	23
HD125 R10-3.0	25.2	3.0	334	352	R9	R11	0.53%	0.8	25
HD125 R11-3.0	25.6	3.0	352	370	R10	R12	0.52%	0.8	27
HD125 R12-3.0	25.9	3.0	370	387	R11	R13	0.51%	0.8	29
HD125 R13-3.0	26.3	3.0	387	404	R12	R14	0.50%	0.8	31
Torrent (T) Self Cleansing - Super Steep Built-in-Fall									
Sections	Weight Excl. Grate (Kg's)	Length (Metres)	Start Invert (mm)	End Invert (mm)	Previous Upstream Section	Next Downstream Section	Built-in-Fall (%)	Max Design Velocity (M/s)	Max Design Flow Rate (L/s) ¹
HD125 T2 ⁴ -3.0	20.1	3.0	162	239	R1	T5 ⁸ or R5	2.51%	1.5	20
HD125 T5 ⁸ -3.0	21.9	3.0	239	316	T2 ⁴ or R4	T9 ¹³ or R9	2.49%	1.6	30
HD125 T9 ¹³ -3.0	25.6	3.0	316	404	T5 ⁸ or R8	R14	2.87%	1.8	50
Zero Fall Shallow (Z1) - 115mm Invert									
Sections	Weight Excl. Grate (Kg's)	Length (Metres)	Start Invert (mm)	End Invert (mm)	Previous Upstream Section	Next Downstream Section	Built-in-Fall (%)	Max Design Velocity (M/s)	Max Design Flow Rate (L/s) ¹
HD125 Z1-3.0	17.5	3.0	115	115	-	R1	0.00%	-	-
Zero Fall (Z5) - 239mm Invert²									
Sections	Weight Excl. Grate (Kg's)	Length (Metres) ⁵	Start Invert (mm)	End Invert (mm)	Previous Upstream Section	Next Downstream Section	Built-in-Fall (%)	Max Design Velocity (M/s)	Max Design Flow Rate (L/s) ¹
HD125 Z5-0.5	3.3	0.5	239	239	T2 ⁴ or R4	T5 ⁸ or R5	0.00%	-	-
HD125 Z5-1.0	6.5	1.0	239	239	T2 ⁴ or R4	T5 ⁸ or R5	0.00%	-	-
HD125 Z5-1.5	9.8	1.5	239	239	T2 ⁴ or R4	T5 ⁸ or R5	0.00%	-	-
HD125 Z5-2.0	13.1	2.0	239	239	T2 ⁴ or R4	T5 ⁸ or R5	0.00%	-	-
HD125 Z5-2.5	16.4	2.5	239	239	T2 ⁴ or R4	T5 ⁸ or R5	0.00%	-	-
HD125 Z5-3.0	20.1	3.0	239	239	T2 ⁴ or R4	T5 ⁸ or R5	0.00%	-	-

1. Maximum design flow rate is calculated using the Mannings n = 0.012 with 30mm freeboard below grating
 2. Zero Fall Sections are used where there is surface slope or to extend overall length of "River" sections
 3. Channel sections can be custom designed (% fall, length) to suit site specific conditions
 4. R1 Sections (0.5 L/m multiples) are used to vary overall length
 5. Overall drain length can be cut to size to less than 0.5m multiples if required, extra charges will apply.

GALVANISED MESH GRATING (125 GMG)

Hi-Flo Grating - High Flow Rate

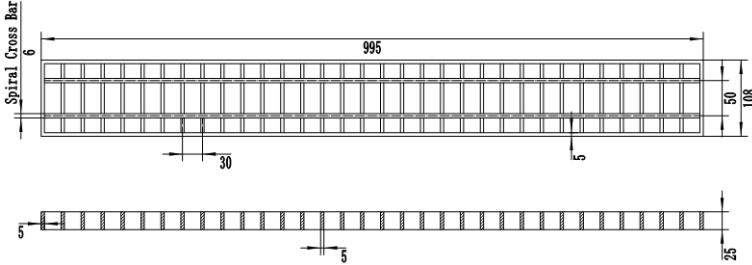

POWERED COATED DUTILE IRON GRATING (125 SGG)

Shoe-guard Grating – Heel Guard Compliant

Length 500mm, 8mm Slot

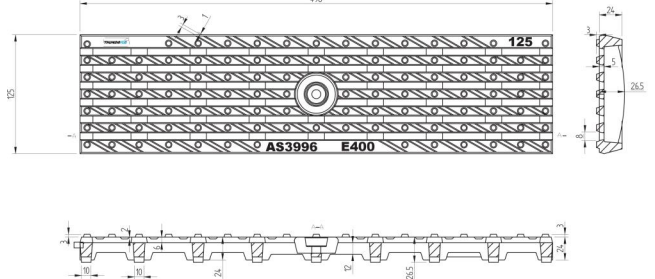

RATED D210 (AS3996) – TESTED BY OPUS LABORATORIES

MAX FLOW RATE	One side 7.0 L/s/m
	Two sides 11.0 L/m/s

RATED E400 (AS3996) – TESTED BY OPUS LABORATORIES N.Z.

MAX FLOW RATE	One side 5.5 L/s/m
	Two sides 11.0 L/s/m

INLINE SUMP (125 ILS)

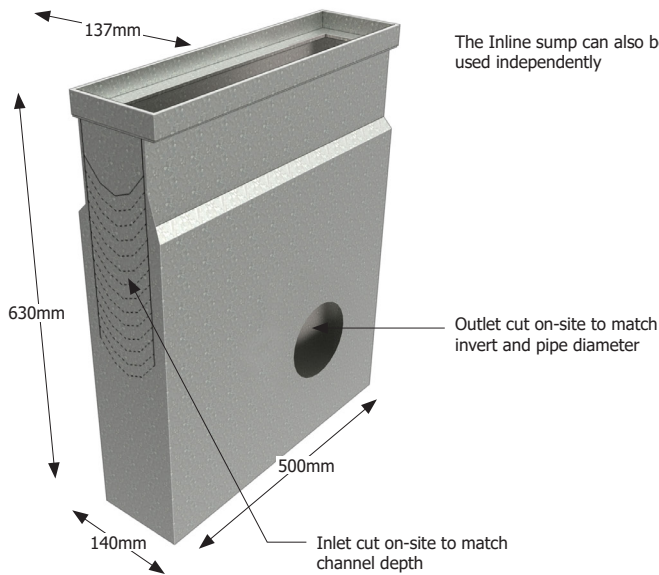

INSTALLATION GUIDE

CONCRETE BOTH SIDES

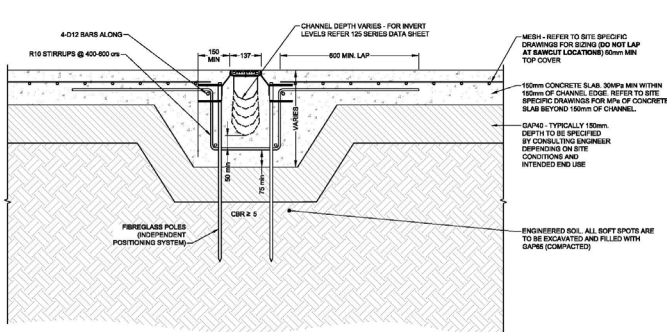

ASPHALT BOTH SIDES

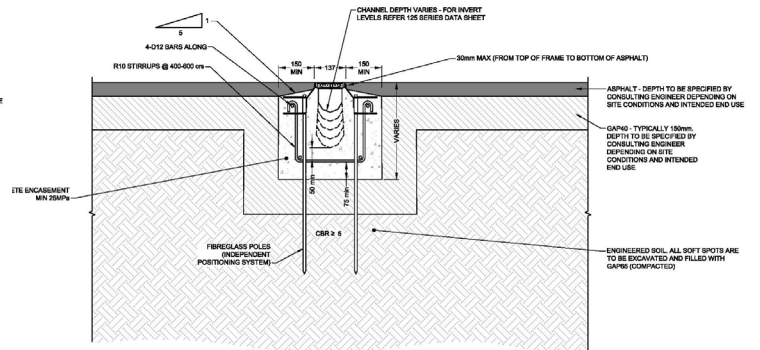

The Installation Guides can be downloaded from website - www.thundaflo.com/downloads